

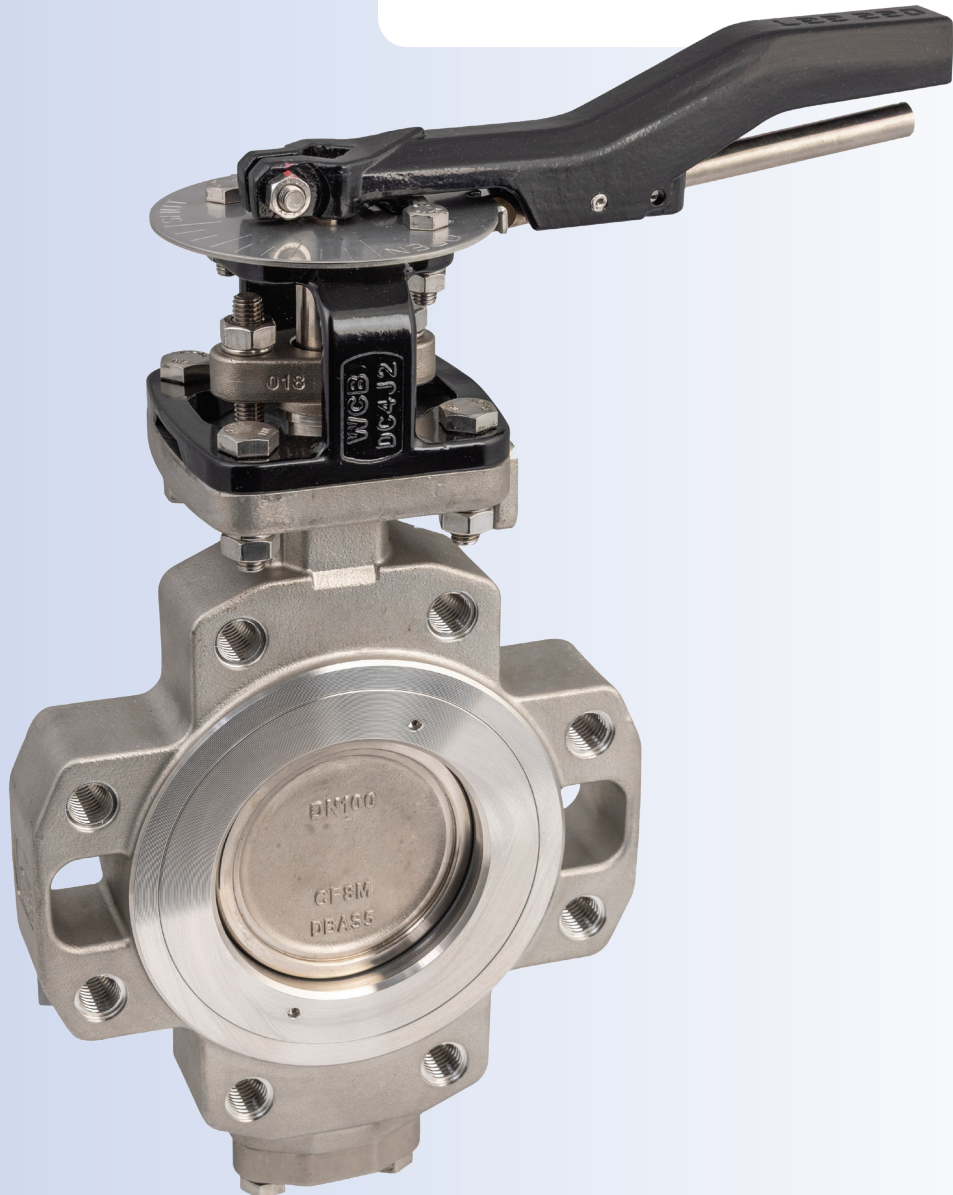

DOUBLE OFFSET HIGH PERFORMANCE

# MD BUTTERFLY VALVES





# MD INFORMATION & OPTIONS

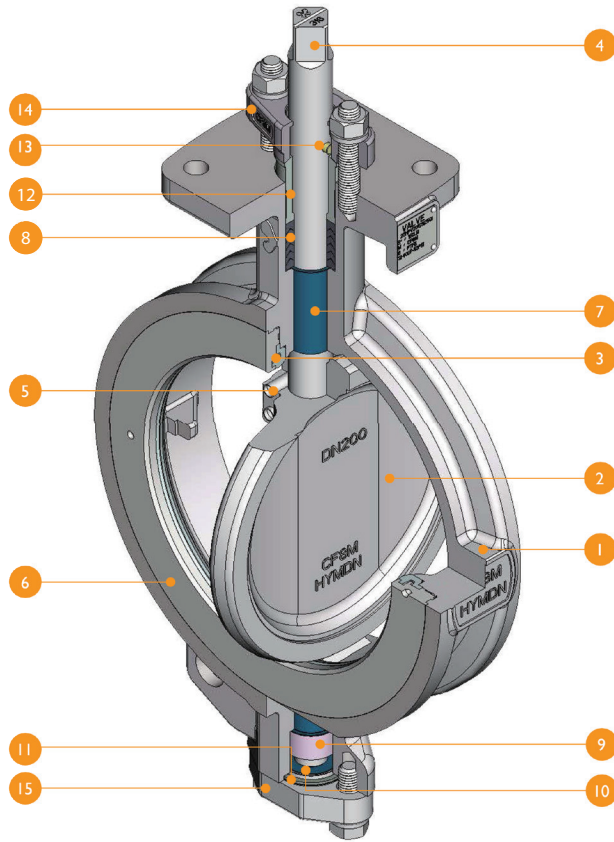

#	PART	MATERIALS	QTY.
1	BODY	ASTM A216 Grade WCB, ASTM A351 Grade CF8, ASTM A351 Grade CF8M	1
2	DISC	ASTM A351 Grade CF8, ASTM A351 Grade CF8M	1
3	SEAT	PTFE, RTFE	1
4	UPPER STEM	A182 Grade F6A, A182 Grade F304, A182 Grade F316, 17-4 PH, UNS S31803	1
5	DISC   PIN	A182 Grade F316L	2
6	SEAT   RETAINER	ASTM A351 Grade CF8M, ASTM A351 Grade CF8	1
7	SEAT   RETAINER   SPRING	A182 Grade F316	1
8	SEAT   RETAINER   PIN	PTFE	1
9	UPPER STEM   BUSHING	PTFE+SS316L	2
10	UPPER STEM   PACKING	PTFE, RTFE, Graphite	1
11	LOWER STEM   THRUST RING	ASTM A351 Grade CF8M	1
12	LOWER STEM   THRUST PLATE	PTFE+SS316L	1
13	BODY   BOTTOM COVER   GASKET	RTFE, Graphite	1
14	UPPER STEM   PACKING GLAND	ASTM A351 Grade CF8M	1
15	ANTI-BLOWOUT-PIN	A182 Grade F316	1
16	UPPER STEM   FLANGE	ASTM A351 Grade CF8M	1
17	BODY   BOTTOM COVER	ASTM A351 Grade CF8M	1
18	UPPER STEM   FLANGE   STUD	Stainless Steel	2
19	UPPER STEM   FLANGE   STUD   WASHER	Stainless Steel	2
20	UPPER STEM   FLANGE   STUD   NUT	Stainless Steel	2
21	BODY   BOTTOM COVER   BOLT	Stainless Steel	2
22	BODY   BOTTOM COVER   BOLT   WASHER	Stainless Steel	2



Cincinnati OH, 45246  
513-499-3820  
www.m-zcontrols.com

Distributed By:

# MD TORQUE TABLES

## TORQUE (in-lbs) MD-CLASS 150

SIZE	MD-CLASS 150 TORQUE (in-lbs)							
	SOFT SEAT				FIRESAFE			
	87	145	232	285	87	145	232	285
2"	195	239	292	336	274	310	345	389
2-1/2"	212	248	310	354	327	416	460	504
3"	248	319	381	425	389	451	566	673
4"	310	372	487	655	531	628	735	867
5"	389	566	832	1036	743	929	1195	1363
6"	540	743	1115	1372	991	1239	1620	1806
8"	894	1381	2106	2215	1823	2186	2425	2595
10"	1407	2195	3372	3531	2850	3266	3850	4110
12"	2266	3478	5293	6169	4284	4939	5850	7385
14"	3408	5160	7001	7574	6072	7045	8355	9595
16"	5001	7550	10231	12612	8461	9922	11887	15613
18"	6266	9656	13267	16436	10878	12842	15471	17882
20"	9453	14223	19215	23605	15197	17967	21711	28588
24"	14914	22215	29845	36439	22817	27110	32836	37878

## TORQUE (in-lbs) MD-CLASS 300

SIZE	MD-CLASS 300 TORQUE (in-lbs)							
	SOFT SEAT				FIRESAFE			
	285	435	580	725	285	435	580	725
2"	336	434	531	699	398	469	549	717
2-1/2"	372	478	584	761	478	593	699	814
3"	434	558	682	823	673	797	920	1275
4"	726	991	1257	1478	1115	1381	1646	1797
5"	1248	1699	2151	2257	1832	2283	2735	3018
6"	1823	2478	3133	3496	2629	3284	3939	4408
8"	3213	4478	5753	6576	4700	5965	7240	7399
10"	5549	7709	9869	11205	7842	10001	12170	12488
12"	8718	12019	15321	17622	11940	15232	18533	19445
14"	12904	17693	22490	26481	17162	21959	26747	28827
16"	20118	27313	34509	39890	25667	32854	40050	43059
18"	27340	37359	47378	52998	34713	44732	54760	57043
20"	37580	51202	64823	72833	46776	60389	74010	77869
24"	58468	79515	100562	113352	71107	92154	113192	120237



Cincinnati OH, 45246  
513-499-3820  
www.m-zcontrols.com

Distributed By:

# MD TORQUE TABLES

## CV (°OPEN) MD-CLASS 150

MD	150#										
SIZE	10	20	30	40	45	50	60	70	80	85	90
2"	0	8	22	36	44	51	60	69	72	70	70
2-1/2"	2	16	38	61	71	83	109	135	146	152	150
3"	6	33	62	94	108	118	143	176	208	230	227
4"	16	58	106	155	178	213	274	349	433	465	473
5"	20	94	167	230	263	310	391	488	561	604	605
6"	40	147	242	335	382	422	560	729	925	975	1010
8"	66	237	368	509	606	712	985	1296	1640	1715	2004
10"	139	390	595	807	963	1168	1606	3134	2814	3180	3199
12"	204	548	820	1138	1357	1591	2219	3067	4085	4484	4672
14"	264	674	972	1386	1658	1994	2840	3925	5164	5828	5947
16"	384	864	1196	1765	2155	2611	3755	5105	6975	7920	8182
18"	508	1092	1551	2341	2881	3522	5125	7134	9511	10599	11548
20"	626	1294	1792	2651	3304	4082	5919	8256	11429	13126	13813
24"	1047	2251	3178	4563	5543	6568	9277	12932	17093	18328	19021

## CV (°OPEN) MD-CLASS 300

MD	300#										
SIZE	10	20	30	40	45	50	60	70	80	85	90
2"	-	-	-	-	-	-	-	-	-	-	-
2-1/2"	-	-	-	-	-	-	-	-	-	-	-
3"	6	33	62	94	108	118	143	176	208	230	227
4"	16	58	106	155	178	213	274	349	433	465	473
5"	20	94	167	230	263	310	391	488	561	604	605
6"	37	137	225	312	355	393	521	678	860	907	939
8"	62	220	343	473	563	662	916	1206	1525	1595	1864
10"	129	362	554	750	896	1087	1493	1985	2617	2957	2975
12"	190	510	762	1059	1262	1480	2064	2852	3799	4170	4345
14"	246	627	904	1289	1542	1854	2641	3650	4803	5420	5531
16"	357	803	1112	1642	2004	2428	3492	4748	6487	7365	7609
18"	473	1015	1442	2177	2679	3275	4766	6634	8845	9857	10739
20"	583	1204	1667	2466	3073	3797	5504	7678	10629	12207	12846
24"	974	2093	2956	4244	5155	6108	8627	12027	15897	17045	17689



Cincinnati OH, 45246  
513-499-3820  
www.m-zcontrols.com

Distributed By:

# MD PRESSURE-TEMPERATURE

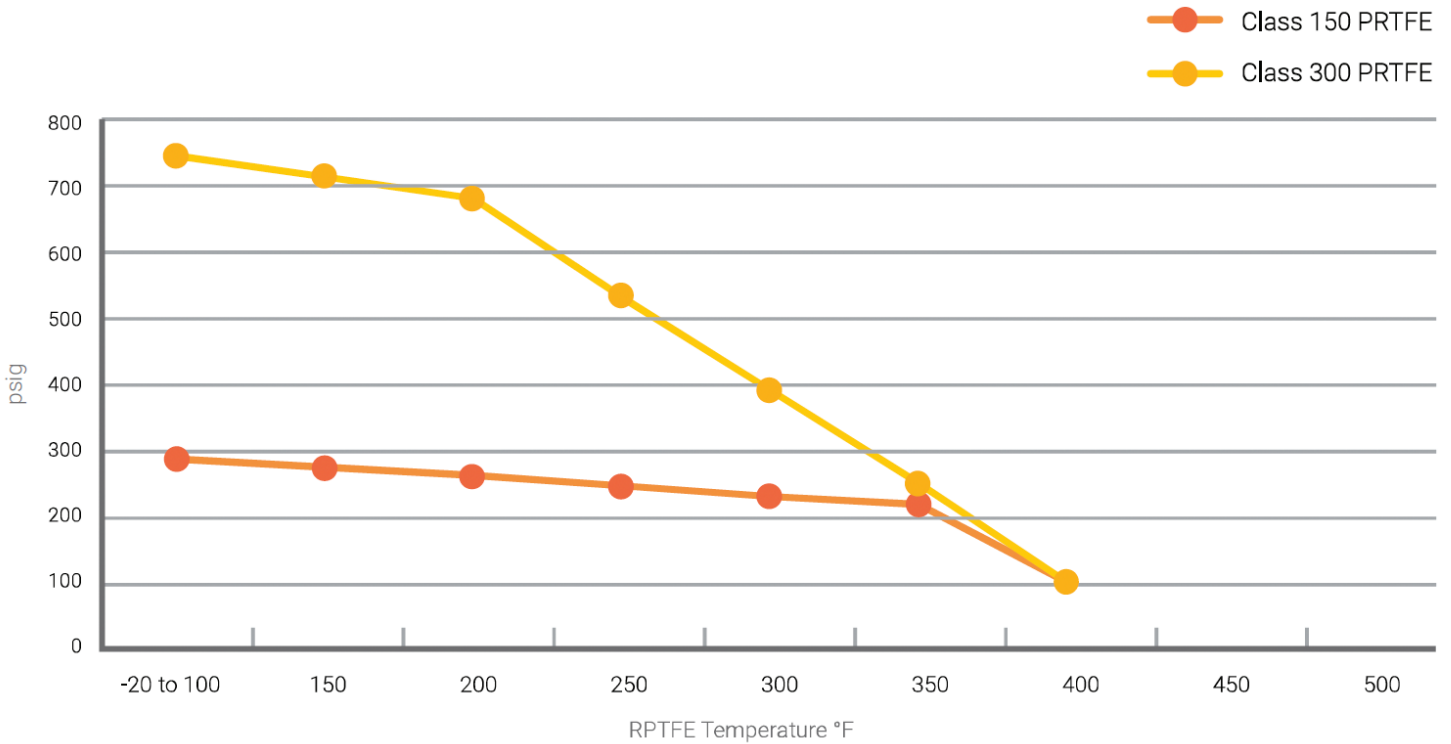
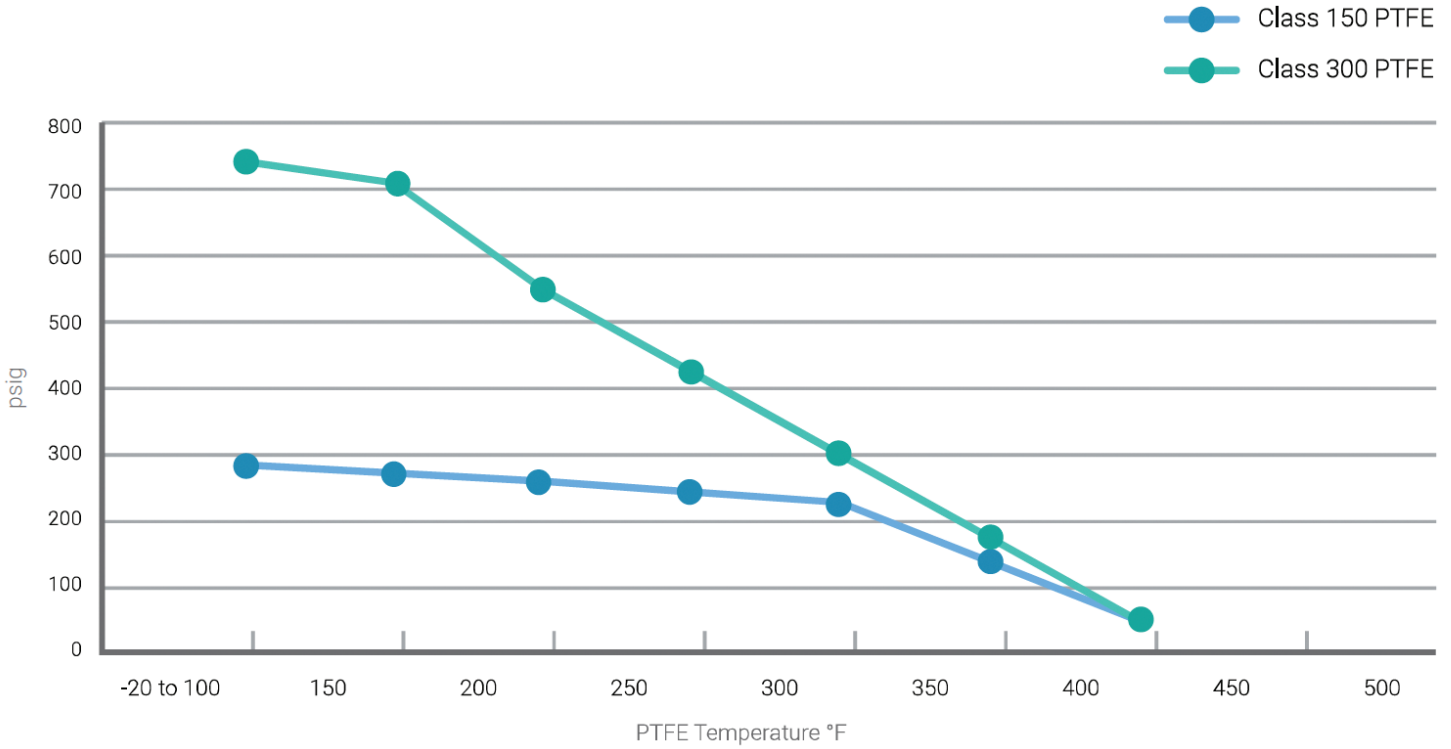

Cincinnati OH, 45246  
513-499-3820  
www.m-zcontrols.com

Distributed By:

# MD DIMENSIONS

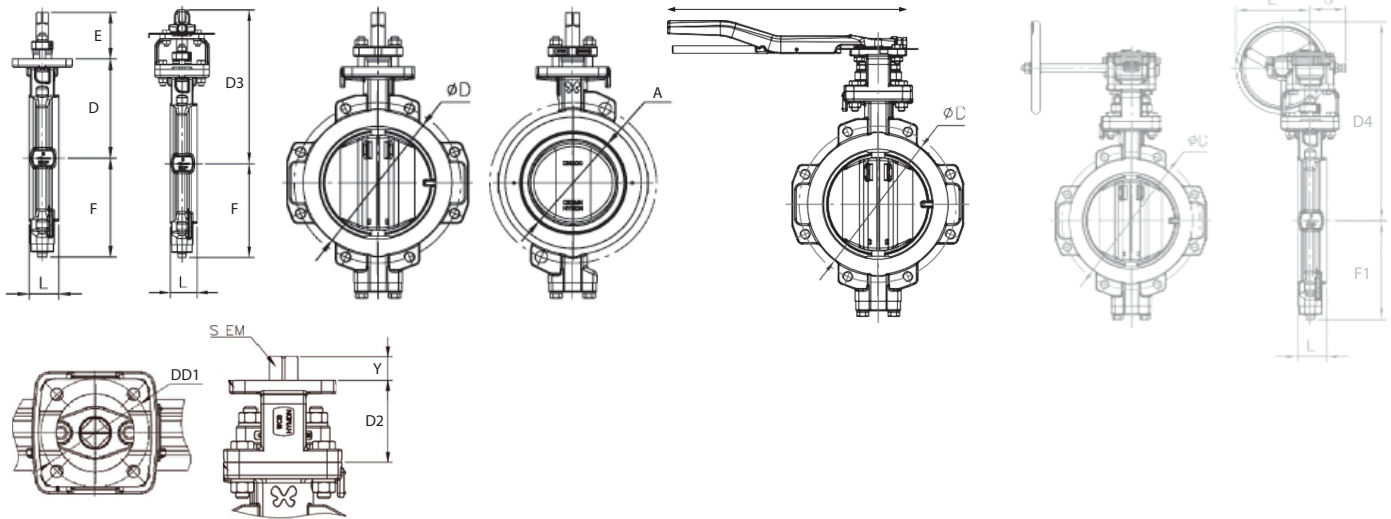

## DIMENSIONS (IN) MD-CLASS 150

SIZE	MD-CLASS 150 DIMENSIONS														WEIGHT			
	BODY									MOUNTING					BODY		BODY W/ HANDLE	
	A	B	C	D	D2	D3	F	J	L	ISO5211	DD1	AD	E	Y	LUG	WAFER	LUG	WAFER
2"	1.81	0.433	8.66	5.04	2.76	9.760	4.65	3.740	1.77	F07	2.756	0.71	3.39	0.63	15.0	13.0	20.0	18.0
2-1/2"	2.40	0.433	8.66	5.35	2.76	10.080	4.96	4.409	1.89	F07	2.756	0.71	3.39	0.63	18.0	15.0	22.0	20.0
3"	2.99	0.551	8.66	5.51	2.76	10.240	5.28	4.961	1.89	F07	2.756	0.71	3.39	0.63	20.0	18.0	24.0	22.0
4"	3.78	0.551	8.66	5.91	2.76	10.630	5.67	6.102	2.13	F07	2.756	0.71	3.39	0.63	29.0	20.0	33.0	24.0
5"	4.65	0.669	11.81	6.69	2.76	11.420	7.01	7.244	2.24	F07	2.756	0.87	3.50	0.75	40.0	26.0	46.0	33.0
6"	5.63	0.669	11.81	7.28	2.76	12.010	7.48	8.465	2.24	F07	2.756	0.87	3.50	0.75	44.0	31.0	51.0	37.0
8"	7.40	0.748	15.75	8.46	3.15	13.780	8.43	10.512	2.44	F10	4.016	0.98	3.98	0.83	64.0	44.0	75.0	55.0
10"	9.29	0.866	-	10.24	3.15	-	10.00	12.838	2.76	F10	4.016	1.10	4.09	0.94	104.0	71.0	-	-
12"	11.06	1.063	-	11.42	3.94	-	11.73	14.764	3.19	F12	4.724	1.38	5.08	1.14	152.0	106.0	-	-
14"	12.60	1.260	-	12.60	3.94	-	12.91	16.378	3.62	F12	4.724	1.65	5.28	1.34	203.0	143.0	-	-
16"	14.61	1.417	-	14.57	4.72	-	14.84	18.898	4.02	F14	5.511	1.97	6.22	1.50	302.0	216.0	-	-
18"	16.54	1.417	-	15.55	4.72	-	15.83	21.024	4.49	F14	5.511	1.97	6.22	1.50	381.0	289.0	-	-
20"	18.46	1.811	-	16.93	4.72	-	17.20	23.150	5.00	F14	5.511	2.36	6.61	1.89	534.0	377.0	-	-
24"	21.61	-	-	18.90	5.91	-	19.37	27.244	6.06	F16	6.496	2.56	9.45	3.54	833.0	606.0	-	-



Cincinnati OH, 45246  
513-499-3820  
www.m-zcontrols.com

Distributed By:

# MD DIMENSIONS

## DIMENSIONS (IN) MD-CLASS 300

SIZE	MD-CLASS 300 DIMENSIONS														WEIGHT			
	BODY									MOUNTING					BODY		BODY W/ HANDLE	
	A	B	C	D	D2	D3	F	J	L	ISO5211	DD1	AD	E	Y	LUG	WAFER	LUG	WAFER
2"	1.81	0.551	8.66	5.04	2.76	9.760	4.65	3.740	1.77	F07	2.756	0.71	3.39	0.63	18.0	13.0	22.0	18.0
2-1/2"	2.40	0.551	8.66	5.36	2.76	9.920	4.96	4.409	1.89	F07	2.756	0.71	3.39	0.63	20.0	15.0	24.0	20.0
3"	2.99	0.551	8.66	5.51	2.76	10.240	5.28	4.961	1.89	F07	2.756	0.71	3.39	0.63	24.0	18.0	29.0	22.0
4"	3.78	0.551	8.66	5.91	2.76	10.630	5.67	6.102	2.13	F07	2.756	0.71	3.39	0.63	29.0	20.0	33.0	24.0
5"	4.65	0.669	11.81	6.69	2.76	11.420	7.01	7.244	2.24	F07	2.756	0.87	3.50	0.75	40.0	26.0	46.0	33.0
6"	5.63	0.748	15.75	7.87	3.15	13.190	7.83	8.819	2.32	F10	4.016	0.98	3.98	0.83	57.0	40.0	68.0	51.0
8"	7.40	0.866	-	9.45	3.15	-	9.21	11.024	2.87	F10	4.016	1.10	4.09	0.94	95.0	62.0	-	-
10"	9.29	1.063	-	10.63	3.94	-	10.94	13.583	3.27	F12	4.724	1.38	5.08	1.14	157.0	115.0	-	-
12"	11.06	1.260	-	12.20	3.94	-	12.52	15.551	3.62	F12	4.724	1.65	5.28	1.34	225.0	159.0	-	-
14"	12.60	1.417	-	14.17	4.72	-	14.45	17.323	4.61	F14	5.511	1.97	6.22	1.50	355.0	231.0	-	-
16"	14.61	1.811	-	15.16	4.72	-	15.43	19.488	5.24	F14	5.511	2.36	6.61	1.89	481.0	326.0	-	-
18"	16.54	-	-	16.73	5.91	-	17.20	22.047	5.87	F16	6.496	2.56	9.45	3.54	697.0	472.0	-	-
20"	18.46	-	-	17.72	5.91	-	18.31	24.488	6.26	F16	6.496	2.95	9.65	3.74	871.0	597.0	-	-
24"	21.61	-	-	20.87	7.87	-	21.06	28.347	7.13	F25	10.00	3.54	12.20	4.33	1418.0	952.0	-	-



Cincinnati OH, 45246  
513-499-3820  
www.m-zcontrols.com

Distributed By:

# MD OPTIONS

## HOW TO ORDER

1) Series	2) Body Material	3) Connection	4) Size	5) Seat Material
MD	S- Stainless Steel C- Carbon Steel	L1- 150# LUG W1- 150# Wafer With Guide Holes W3- 300# Wafer With Guide Holes L3- 300# LUG	0200- 2" 0250- 2-1/2" 0300- 3" 0400- 4" 0500- 5" 0600- 6" 0800- 8" 1000- 10" 1200- 12" 1400- 14" 1600- 16" 1800- 18" 2000- 20" 2400- 24"	R- RTFE P- PTFE F- RTFE + 316SS Fire Safe Ring M- Inconel 718"
6) Disc Material	7) Stem Material	8) Stem Bushing Material	9) Operator	
S- Stainless Steel	R- A182 Grade F316 A- A182 Grade F6A B- A182 Grade F304 P- 17-4 PH	P- PTFE+SS316L	X- None G- Gear Operator P- 10-Position Handle	

**How to Order:** {1}{2}-{3}-{4}-{5}{6}{7}{8}-{9}  
**Example:** MDS-L1-0200-RSRP-P



Cincinnati OH, 45246  
 513-499-3820  
[www.m-zcontrols.com](http://www.m-zcontrols.com)

**Distributed By:**